

2 Channels CAN Controller – USB 2.0

Two Channels Multipurpose communications applications- Protocol Converter

Features

CAN Bus:

- High Speed CAN interface according to ISO 11898-2
- Time-stamped CAN messages
- Supports 11-bit (CAN 2.0A) and 29-bit (CAN 2.0B active) identifiers
- Bit rates 10 to 1000 kbps
- Reliable error handling
- Low Power consumption
- NEMA Compliance
- Isolated CAN Channels

USB interface:

- Fully compliant with USB 2.0 spec.
- Supports Control, Bulk, Interrupt and Isochronous endpoints
- Endpoint Maximum packet size selection by software
- Supports DMA transfers with the DMA RAM of 16KB
 - USB host controller
- OHCI compliant
- Two downstream ports

Block Diagram and Operational Overview

The **M.2-CAN-2** board is engineered around the NXP LPC2387 microcontroller. This highly integrated 32 bits microcontroller based on the ARM7TDMI-S processor, has a very low power consumption and features 512 kB of on-chip high-speed flash memory. It incorporates several communications ports, specifically a USB full-speed Device/Host/OTG Controller with 4 kB of endpoint RAM, and two Controller Area Network (CAN) channels.

The device controller enables 12 Mbit/s data exchange with a USB host controller. It consists of a register interface, serial interface engine, endpoint buffer memory, and a DMA controller. The serial interface engine decodes the USB data stream and writes data to the appropriate endpoint buffer. The status of a completed USB transfer or error condition is indicated via status registers.

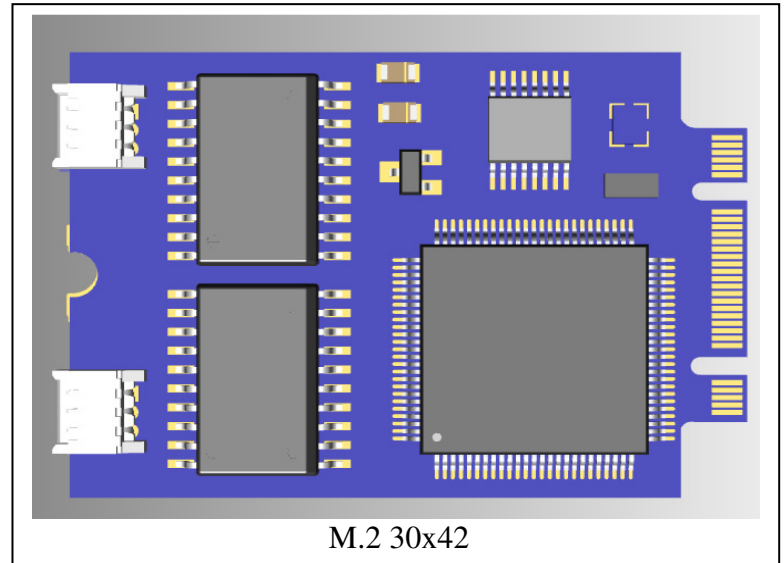
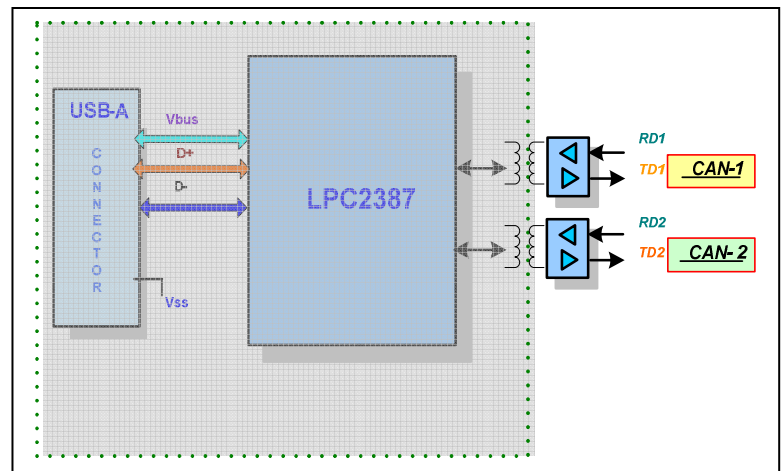

Fig.1



Block Diagram

An interrupt is also generated if enabled. When enabled, the DMA controller transfers data between the endpoint buffer and the USB RAM.

The Controller Area Network (CAN) is a serial communications protocol that efficiently supports distributed real-time control with a very high level of security.

Its domain of application ranges from high-speed networks to low-cost multiplex wiring.

Applications:

This board is optimally suited for communications gateway and protocol converters. This is a perfect solution for:

- Avionics equipment
- Avionic data communication systems
- Medical systems
- Industrial controls
- Others

Software Support:

LPC2387 Device Specifications:

- Fully compliant with USB 2.0 Specification (full speed).
- Supports 32 physical (16 logical) endpoints with a 4 kB endpoint buffer RAM.
- Supports Control, Bulk, Interrupt and Isochronous endpoints.
- Scalable realization of endpoints at run time.
- Endpoint Maximum packet size selection (up to USB maximum specification) by software at run time.
- Supports SoftConnect and GoodLink features.
- While USB is in the Suspend mode, the LPC2387 can enter one of the reduced power modes and wake up on USB activity.
- Supports DMA transfers with the DMA RAM of 16 kB on all non-control endpoints.
- Allows dynamic switching between CPU-controlled and DMA modes.
- Double buffer implementation for Bulk and Isochronous endpoints.

- Two CAN controllers and buses.
- Data rates to 1 Mbit/s on each bus.
- 32-bit register and RAM access.
- Compatible with CAN specification 2.0B, ISO 11898-1.
- Global Acceptance Filter recognizes 11-bit and 29-bit receive identifiers for all CAN buses.
- Acceptance Filter can provide FullCAN-style automatic reception for selected Standard Identifiers.
- FullCAN messages can generate interrupts.

Mechanical: Environmental:

- Size – M.2 Module
30 mm x 42 mm
- Power – T.B.D.
- Front panel I/O
- Vibration – 0.5G, 20-2000 Hz rand
- Shock – 20G, 11 msec, ½ sine
- Weight – tbd
- MTBF – >250,000 hours

Operating Environment:

- Operating temperature
Commercial: 0 to +70 °C
Optional: -40 °C to +85 °C
- Non-operating: -60 °C to +120 °C
- Humidity – 5 to 90% (non-cond)
- Altitude – 0 to 10,000 feet

Ordering Information:

Part number: M.2 –CAN-2: CAN Bus and USB interface on M.2 22x60

Part number: M.2 –CAN-2I: Same as above with -40 to +85 C M.2 22x60

Part number: M.2 –CAN-2ICC: Same -40 to +85 C Conformal Coated

Optional Accessories

Part number: CBL-Mini-CAN-12 CAN Cable, 12 Inch Micro to DB9